



**PULL MY FINGER!**



PLACE SERIAL NUMBER LABEL HERE



# FACTORY CONTACT INFORMATION



BAY TEK GAMES INC.  
Pulaski Industrial Park  
1077 East Glenbrook Drive  
Pulaski, WI 54162 U.S.A.  
[www.baytekgames.com](http://www.baytekgames.com)

*Our Vision:*

*We aspire to be the best in the world at developing and manufacturing coin operated games for our customers.*

**JOIN SERVICE FIRST NETWORK!**

This free service is intended to keep you up to date on the latest game information, early notification of parts specials, pertinent technical bulletins, updates on retro fit parts, software upgrades, & much more. Log on to:  
[www.baytekgames.com/parts](http://www.baytekgames.com/parts)  
& then click on the Service First icon.

8 AM - 5 PM C.S.T. MON - FRI

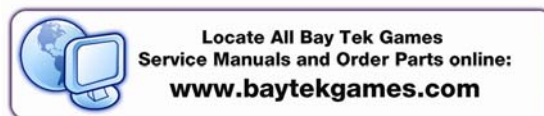

**SALES**

P: 920.822.3951  
F: 920.822.8936  
[sales@baytekgames.com](mailto:sales@baytekgames.com)

**PARTS**

P: 920.822.3951 x 1101  
F: 920.822.1496  
[parts@baytekgames.com](mailto:parts@baytekgames.com)

**SERVICE:**

P: 920.822.3951 X 1102  
F: 920.822.1496  
[service@baytekgames.com](mailto:service@baytekgames.com)

All games proudly manufactured at our factory in Pulaski, Wisconsin U.S.A.

# TABLE OF CONTENTS

FACTORY CONTACT INFORMATION	2
TABLE OF CONTENTS	3
INTRODUCTION	4
INSPECTION	4
SPECIFICATIONS	5
SAFETY PRECAUTIONS	5
HOW TO PLAY	6
QUICK SET-UP GUIDE	7-9
DETAILED OPERATIONS/ MAIN MENU	10
DIAGNOSTICS	11
CREDITS/BALLS PER PLAY SETTINGS	12
TICKET PATTERN SETTINGS	13-14
BIG BONUS SETTINGS	15
VOLUME SETTINGS	16
GAME STATISTICS	17-18
HOW TO: INSTALL BILL ACCEPTOR	19
CIRCUIT BOARD WIRING	20
CABLE DIAGRAMS	21-25
TROUBLESHOOTING GUIDE	26-30
POWER SUPPLY DIAGNOSTICS	31
BILL ACCEPTOR DIAGNOSTICS	32
PARTS LIST	33
PART IDENTIFICATION	34-35
DECAL IDENTIFICATION	36
WIRING DIAGRAMS	37-40
MAINTENANCE LOG	41
TECHNICAL SUPPORT	42
WARRANTY	43

# WELCOME TO: Pull My Finger

Congratulations on your Pull My Finger™ purchase!

You already know this product delivers much more than an action-filled game with big profits. Pull My Finger™ is, in simple terms, the epitome of goofy fun! It replicates the kind of fun we had as kids, and has the innate ability to sweep a family with laughter in a matter of seconds!

Please take a moment to read through this manual and be sure to contact our factory if you have any questions, or would like some more information. Pull My Finger™ has built in playfield diagnostics, automatic data tracking (viewable on the marquee displays), dual ticket trays, and a sweet choreography package that keeps people playing...and laughing...and playing... and, well you get the point!  
Enjoy!

Your business is important to us and we hope you enjoy this game as much as we do!

*Your Friends at Bay Tek Games*



## GAME INSPECTION

Inspect the game for any damaged, loose, or missing parts. If damage is found, please contact your freight carrier first. Then, contact Bay Tek Games Service Department at 920.822.3951 or e-mail them at [service@baytekgames.com](mailto:service@baytekgames.com) for further assistance.

# SPECIFICATIONS

WEIGHT	
WEIGHT	675 lbs.
SHIP WEIGHT	755 lbs.

DIMENSIONS	
WIDTH	49"
DEPTH	32 1/4"
HEIGHT	91"









OPERATING TEMPERATURE	
80 - 100 Degrees	Fahrenheit
26.7 - 37.8 Degrees	Celsius

POWER REQUIREMENTS			
INPUT VOLTAGE RANGE	110 to 120 VAC	or	220 to 240 VAC
INPUT FREQUENCY RANGE	50 HZ	to	60 HZ

MAX START UP CURRENT
1.6 AMPS @ 115 VAC
0.8 AMPS @ 230 VAC

OPERATING CURRENT
1.3 AMPS @ 115 VAC
.65 AMPS @ 230 VAC

# SAFETY PRECAUTIONS

	<b>DANGER</b>	
DO NOT perform repairs or maintenance on this game with the power ON. Unplug the unit from the wall outlet or shut off the power at the power strip located inside the game cabinet.		
	<b>WARNING</b>	
Use of flammable substances can cause severe burns or serious injury. Always use NON-FLAMMABLE solvents for cleaning. DO NOT use gasoline, kerosene, or thinners.		
	<b>CAUTION</b>	
Lifting heavy objects can cause back, neck, or other injuries. Be sure adequate lifting and moving devices are available when unloading, unpacking, and moving this game.		
	<b>ATTENTION</b>	
Be sure the electrical power matches the game requirements. See the serial number decal located on the back of the game cabinet. Always plug game into a grounded circuit. If the supply cord is damaged, it must be replaced by a special cord or assembly available from the manufacturer or its service agent.		

# HOW TO PLAY: Pull My Finger

*Pull My Finger™* is a bright and colorful ticket redemption game that encourages players to pull the monkey's finger, which shoots a ball into the playfield where six targets are located.

The targets display alternating ticket values for an added challenge. If timing and accuracy are on point, players can win the big bonus. This selectable bonus ranges from 25 tickets all the way up to a whopping 1000 bonus tickets! (Factory default is 250)

If the ball does not go straight into a target, automatic flippers have been installed on the playfield to keep the ball bouncing until it is launched into a target.

The large, bright and colorful cabinet draws players to this simple ticket redemption game, while the charismatic monkey keeps kids of all ages highly entertained time and time again!

Standard features include: dual ticket dispensers, adjustable bonus patterns, built in diagnostics, and performance tracking software.



# QUICK SET-UP GUIDE

## Tools needed:

1/2" socket & ratchet  
5/32" Allen wrench **or** drill with #2 square bit  
7/16" socket & ratchet

Locate the package of keys (taped to the front of the game). It should include five sets of either B10 or 644 keys, and one set of 631 keys.

Open the cashbox door with the 631 key, and remove the hardware packet and power cord.



Remove the lower back door with two B10 or 644 keys, and take out the hand assembly and guard.



Also remove the bag of balls (16 total), and place them in the ball chute

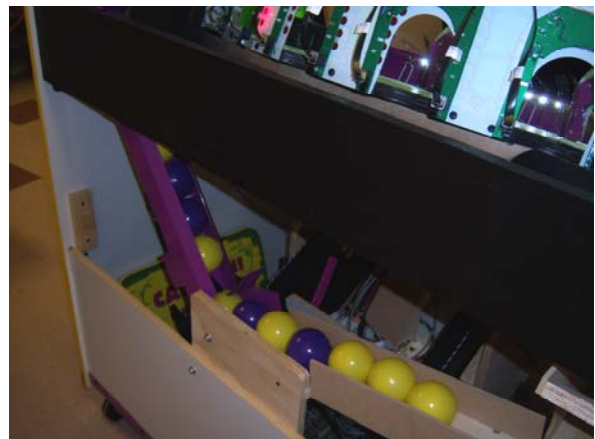

# QUICK SET-UP GUIDE, cont.

Attach the guard to the side of the cabinet with the three 2" carriage bolts, three flat washers, and three 5/16" locknuts.

Make sure the washers go on the inside of the cabinet, between the wood and the lock nuts.



Attach the hand assembly with four black self-tapping square bit screws and split washers.



# QUICK SET-UP GUIDE, cont.

Slide the marquee onto the cabinet from the front, making sure the power cable goes safely down the opening without getting pinched.

Secure the marquee from inside the top back door, inserting 1 1/2" hex bolts with split and flat washers into the holes in either side.

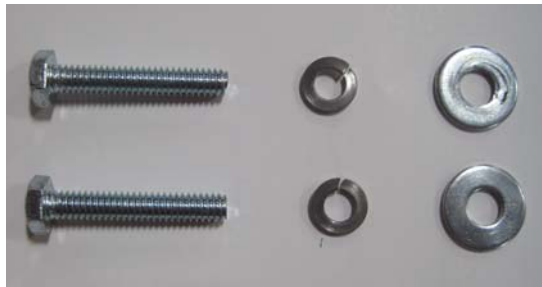

Plug in the marquee power and display cables.

Plug the cable from the cashbox into the back of the cabinet and connect it to a power source.

Push the cabinet to its final location and lock the casters.

Load the ticket trays with tickets.

Power the game on by switching the power strip to "ON".



**Congratulations! You're Ready To Go!**

# DIP SWITCH SETTINGS

<b>DIP 1</b>		
<b>DIP 2</b>		
<b>DIP 3</b>		
<b>DIP 4</b>		

# DETAILED OPERATIONS

## MAIN MENU

1. Access the main menu by pressing the **"MENU BUTTON"** inside the front door of the cabinet and holding down for 4 seconds.
2. Scroll through the menu options shown on the 4-digit display by pressing the **"MENU BUTTON"** repeatedly.
3. Press the **"MENU SELECT"** button to enter and scroll through sub-menus (described in detail below).



## SUB-MENU DESCRIPTIONS

<b>n1</b>	GAME DIAGNOSTICS
<b>n2</b>	CREDITS PER PLAY
<b>n3</b>	BALLS PER PLAY
<b>n4</b>	TICKET PATTERN
<b>n5</b>	BIG BONUS SETTING
<b>n6</b>	GAME VOLUME
<b>n7</b>	ATTRACT MODE VOLUME
<b>n8-11</b>	STATISTICS

# N1– GAME DIAGNOSTICS

The game diagnostics mode will allow you to test the following components to make sure they are working correctly:

## Remove the window from the cabinet

### BALL LAUNCHER SENSOR:

- With the ball launcher empty, make sure the 4-digit display reads “0”
  - Place the ball into the launcher
- If the sensors are working correctly, a “1” should appear on the display in place of the “0”

\*if the display reads “1” while no ball is in the launcher, it is malfunctioning\*

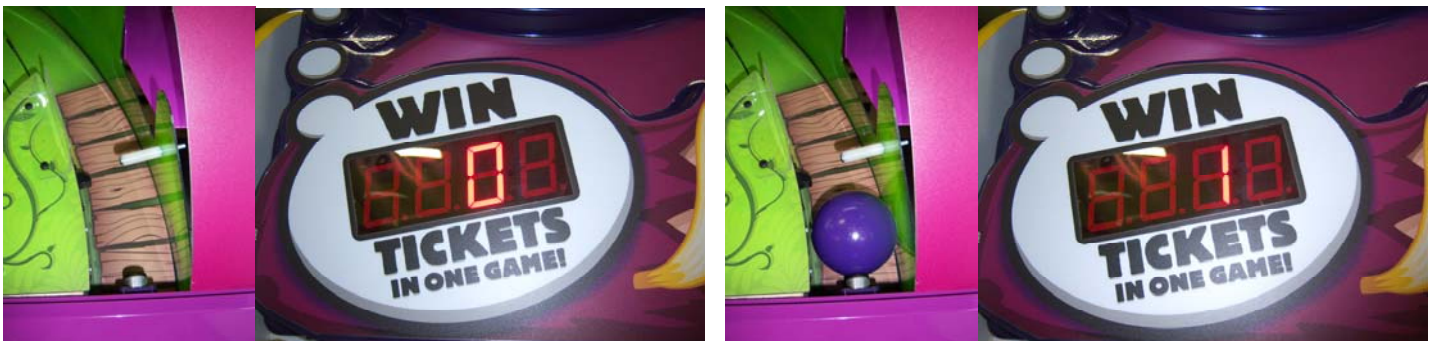

### TARGET SENSORS:

- Place your hand inside each of the targets individually
- The lights around the targets should flash if they are working correctly

\*If the lights come on without an object passing through the target, they are malfunctioning\*



### BALL FLIPPERS:

- Gently push down each flipper to make sure they react



## N2– CREDITS PER PLAY

Scroll through the n2 menu with the “menu select” button.  
Make your selection by pressing the “menu button” and scrolling  
through the remaining menus past n10 to exit the menu.

**Factory default settings are highlighted in yellow.**

CREDITS PER PLAY	0	1	2	3	4	5	6	7	8
PRICE PER PLAY	FREE	\$.25	\$.50	\$.75	\$1.00	\$1.25	\$1.50	\$1.75	\$2.00

## N3– BALLS PER PLAY

Scroll through the n2 menu with the “menu select” button.  
Make your selection by pressing the “menu button” and scrolling  
through the remaining menus past n10 to exit the menu.

**Factory default settings are highlighted in yellow.**

1	2	3	4
---	---	---	---

# N4- TICKET PATTERNS

Scroll through the n3 menu with the “menu select” button.  
Make your selection by pressing the “menu button” and scrolling  
through the remaining menus past n10 to exit the menu.



# N4– TICKET PATTERNS, cont.

Factory default settings are highlighted in yellow.

0			
TARGET #	1	5/S*	TICKETS
	2	5/S*	
	3	20	
	4	30	
	5	40	
	6	100	

1			
TARGET #	1	2/S*	TICKETS
	2	2/S*	
	3	10	
	4	15	
	5	40	
	6	100	

2			
TARGET #	1	1/S*	TICKETS
	2	1/S*	
	3	5	
	4	10	
	5	25	
	6	50	

3			
TARGET #	1	1/S*	TICKETS
	2	1/S*	
	3	5	
	4	10	
	5	15	
	6	25	

4			
TARGET #	1	2/S*	TICKETS
	2	4/S*	
	3	6	
	4	10	
	5	20	
	6	50	

5			
TARGET #	1	1/S*	TICKETS
	2	1/S*	
	3	3	
	4	4	
	5	5	
	6	15	

6			
TARGET #	1	10/S*	TICKETS
	2	10/S*	
	3	5	
	4	10	
	5	25	
	6	50	

**\*S= SKILL TICKETS**

(changes with Big Bonus settings in n4 menu, see pg. 12)

The SKILL SHOT values alternate with the regular pattern values on targets 1 & 2

# N5– BIG BONUS VALUES

Scroll through the n5 menu with the “**menu select**” button.  
 Make your selection by pressing the “**menu button**” and scrolling  
 through the remaining menus past n10 to exit the menu.

**Factory default settings are highlighted in yellow.**

The Big Bonus value is presented on the 4-digit display, and aids in  
 attracting players to the game.

The Big Bonus jumps randomly between targets 3 and 6 on the playfield.

**\*S= SKILL SHOT**

(changes the alternate values displayed on targets 1 & 2)

<b>25</b>			
TARGET #	3 & 6	<b>25</b>	TICKETS
	1 (*S)	<b>15</b>	
	2 (*S)	<b>20</b>	

<b>50</b>			
TARGET #	3 & 6	<b>50</b>	TICKETS
	1 (*S)	<b>10</b>	
	2 (*S)	<b>40</b>	

<b>100</b>			
TARGET #	3 & 6	<b>100</b>	TICKETS
	1 (*S)	<b>10</b>	
	2 (*S)	<b>75</b>	

<b>250</b>			
TARGET #	3 & 6	<b>250</b>	TICKETS
	1 (*S)	<b>30</b>	
	2 (*S)	<b>50</b>	

<b>400</b>			
TARGET #	3 & 6	<b>400</b>	TICKETS
	1 (*S)	<b>40</b>	
	2 (*S)	<b>300</b>	

<b>500</b>			
TARGET #	3 & 6	<b>500</b>	TICKETS
	1 (*S)	<b>50</b>	
	2 (*S)	<b>400</b>	

<b>999</b>			
TARGET #	3 & 6	<b>999</b>	TICKETS
	1 (*S)	<b>100</b>	
	2 (*S)	<b>800</b>	

## N6– GAME VOLUME CONTROL

Scroll through the n6 menu with the “menu select” button.  
Make your selection by pressing the “menu button” and scrolling  
through the remaining menus past n10 to exit the menu.

**Factory default settings are highlighted in yellow.**

0 (OFF)	1	2	3	4	5	6	7	8
------------	---	---	---	---	---	---	---	---

This control is for the volume of the game **while it is being played**, or  
after a coin has been inserted.

A drum beat will play an example volume while scrolling through the  
volume levels.

## N7– ATTRACT VOLUME CONTROL

Scroll through the n7 menu with the “menu select” button.  
Make your selection by pressing the “menu button” and scrolling  
through the remaining menus past n10 to exit the menu.

**Factory default settings are highlighted in yellow.**

0 (OFF)	1	2	3	4	5	6	7	8
------------	---	---	---	---	---	---	---	---

This control is for the volume of the game **while it is NOT being  
played**. This game plays fun, attracting sounds to lure customers to  
play.

A drum beat will play an example volume while scrolling through the  
volume levels.

# GAME STATISTICS

## N8– TARGET HIT COUNTER

In this statistics mode, the **number hits on each target** is displayed.

- Targets 3 and 6 should have the lowest counts on them; this is the reasoning behind the placement of the Big Bonus values

The **average tickets paid out per game** is also shown on the 4-digit display above the playfield.

- This information will assist in finding average payout percentage



## N9– TOTAL NUMBER OF PLAYS

In this statistics mode, the **total number of game plays** is shown on the 4-digit display above the playfield.

- To determine total game income since the last statistics clear, multiply this number by the price per play (set in n2).

$$\begin{array}{l} \# \text{ of} \\ \text{plays} \end{array} \times \begin{array}{l} \$ \text{ per} \\ \text{play} \end{array} = \text{income}$$

For example:

$$172 \text{ plays} \times \$0.50 \text{ per play} = \$86 \text{ income}$$

## N10– SKILL HITS COUNTER

This statistics mode will display a count of “**skill shot**” hits on targets 1 & 2.

A “skill hit” is when the ball goes through target 1 or 2 while the higher alternate value is displayed.

- If these numbers are high, you may have a very skilled player, or “shark”, frequenting your facility. This may cause your game to pay out too many tickets. Because Pull My Finger is a skill-based game, this is a possibility.

The **total number of games played** is shown on the 4-digit display.



## N11– STATISTICS CLEAR

While in n11 mode, **hold down “menu select” for 3 seconds** to clear the statistics in menus n8-n10.

The statistics modes (n8-n10) will display “0” on all targets and 4-digit display when viewed again after clearing.

# HOW TO: INSTALL BILL ACCEPTOR

Tools Needed: 11/32" Nut Driver or socket wrench

- 1.) Remove 4 nuts from bill acceptor plate and 2 from coin mech bolts.
- 2.) Remove black bill acceptor plate.
- 3.) Insert Bill Acceptor.

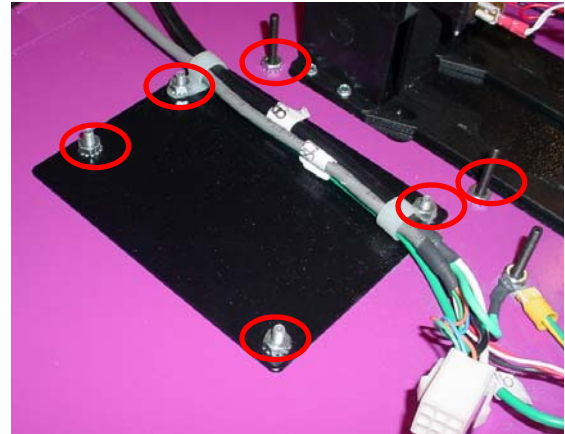
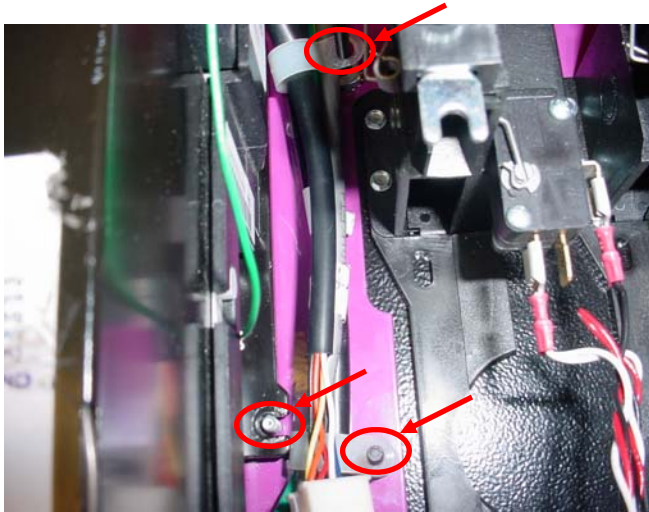

- 4.) Install nuts on bill acceptor plate and coin mech.
- 5.) Route cables as shown in picture.
- 6.) Make sure Bill Acceptor is set to "Always Enabled" and test.

# CIRCUIT BOARD WIRING

## AANEWGEN1 - MAIN BOARD

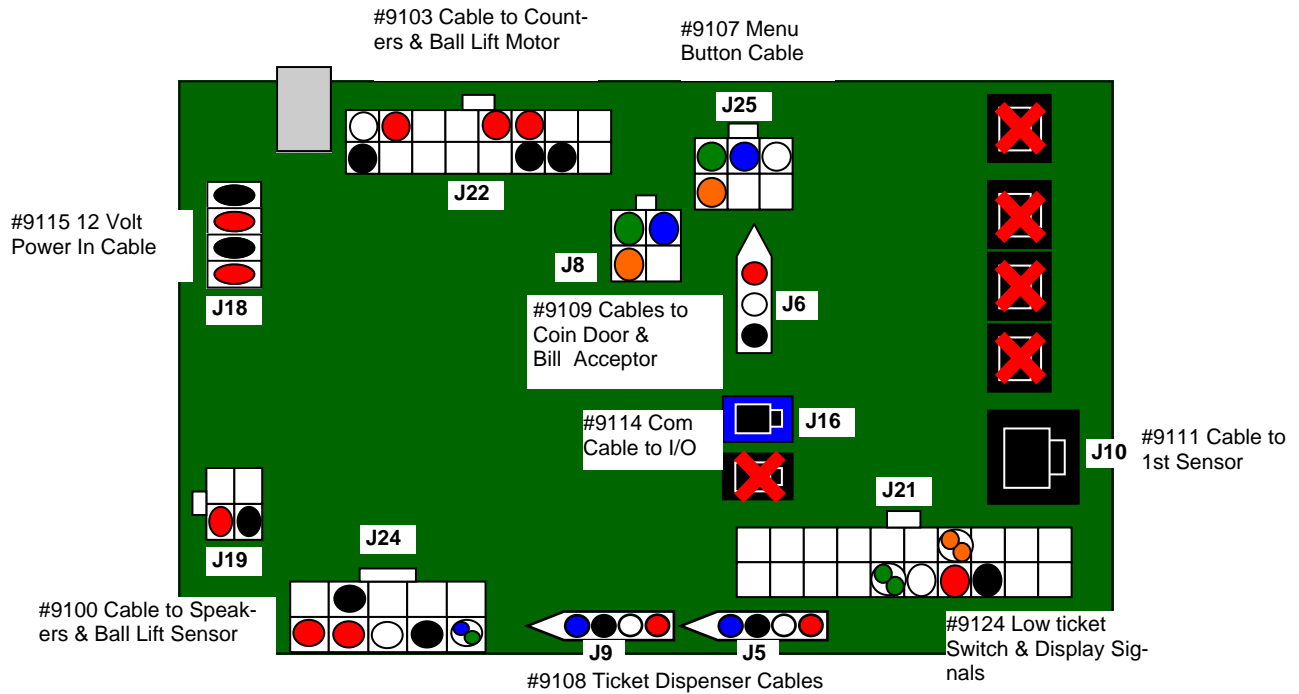

## AACB9107—I/O AUX BOARD

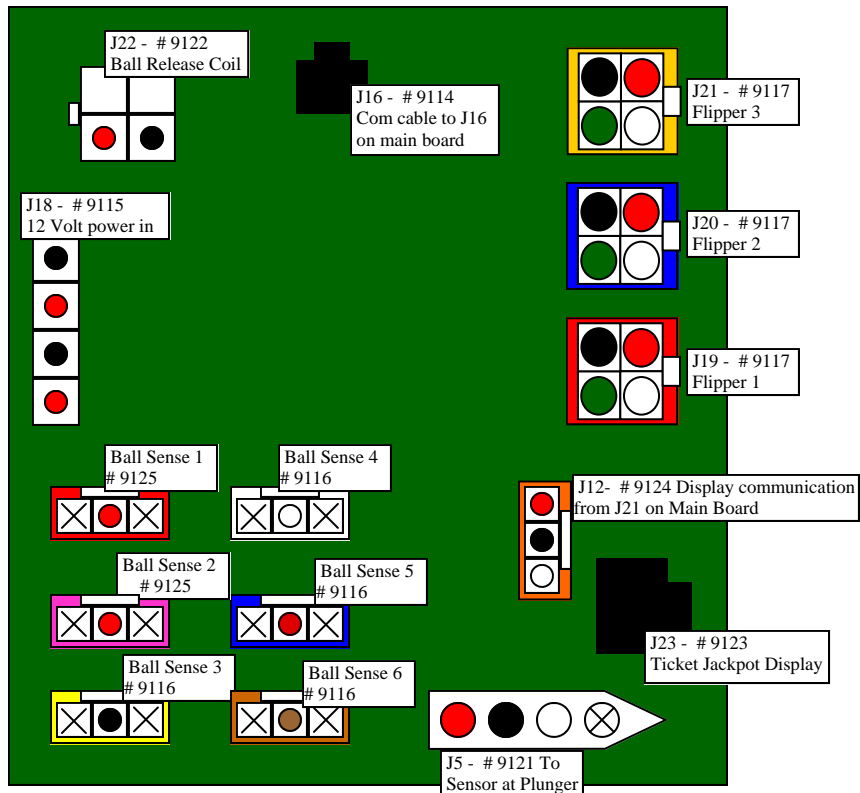

## Coin Door and Bill Acceptor Cable

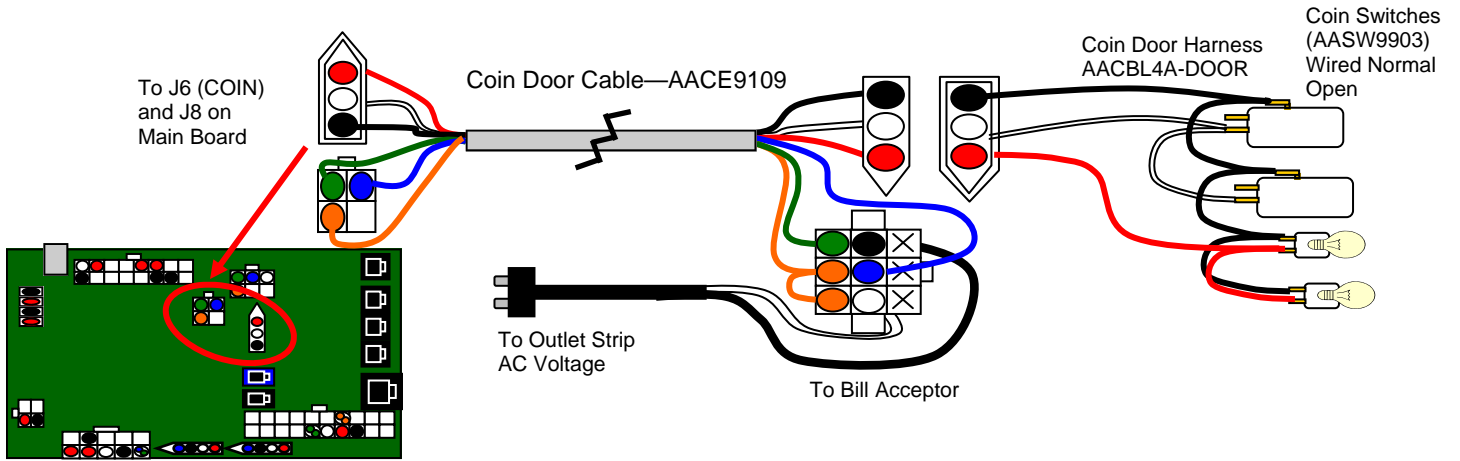

## Ball Lift Sensor & Volume Cable

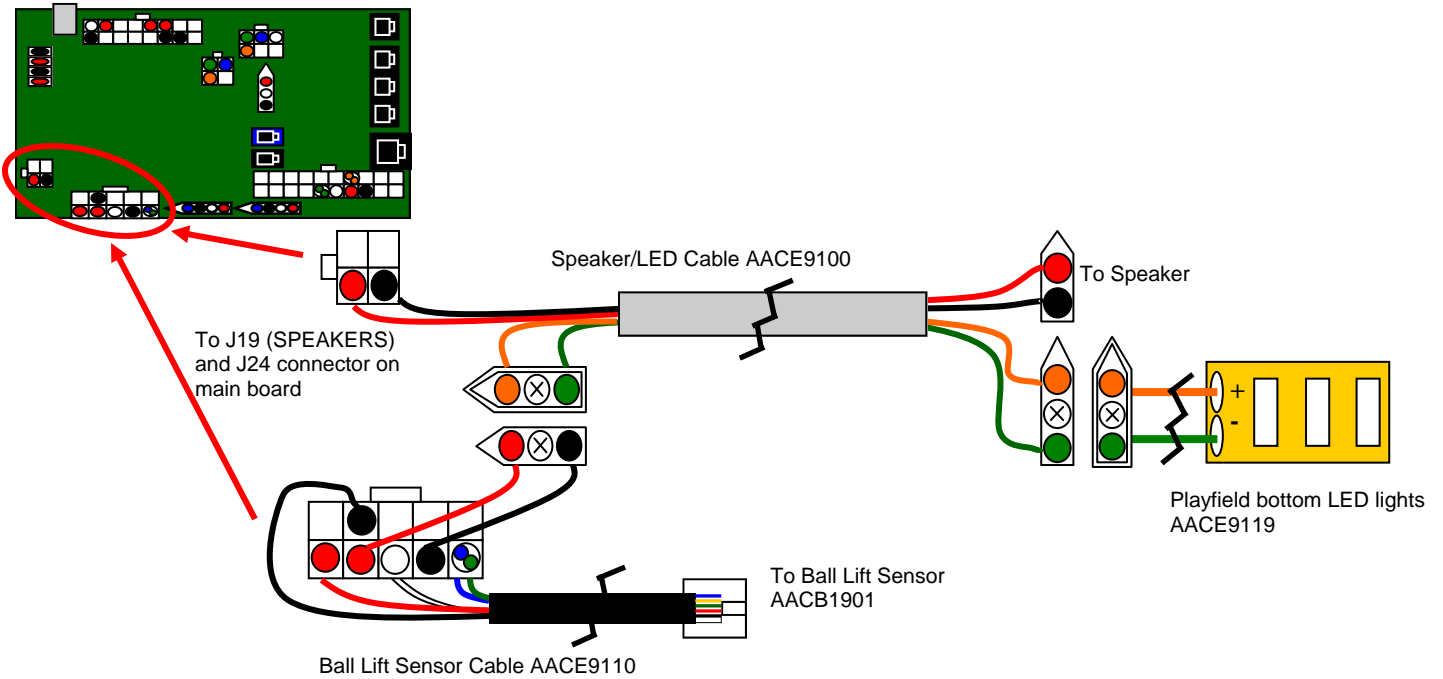

## Menu Buttons Cable—AACE9107

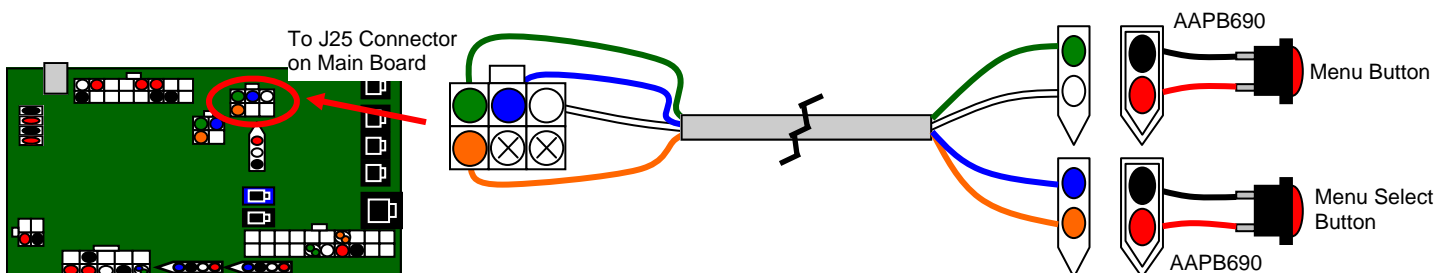

## Ball Lift Motor & Counters Cable—AACE9103

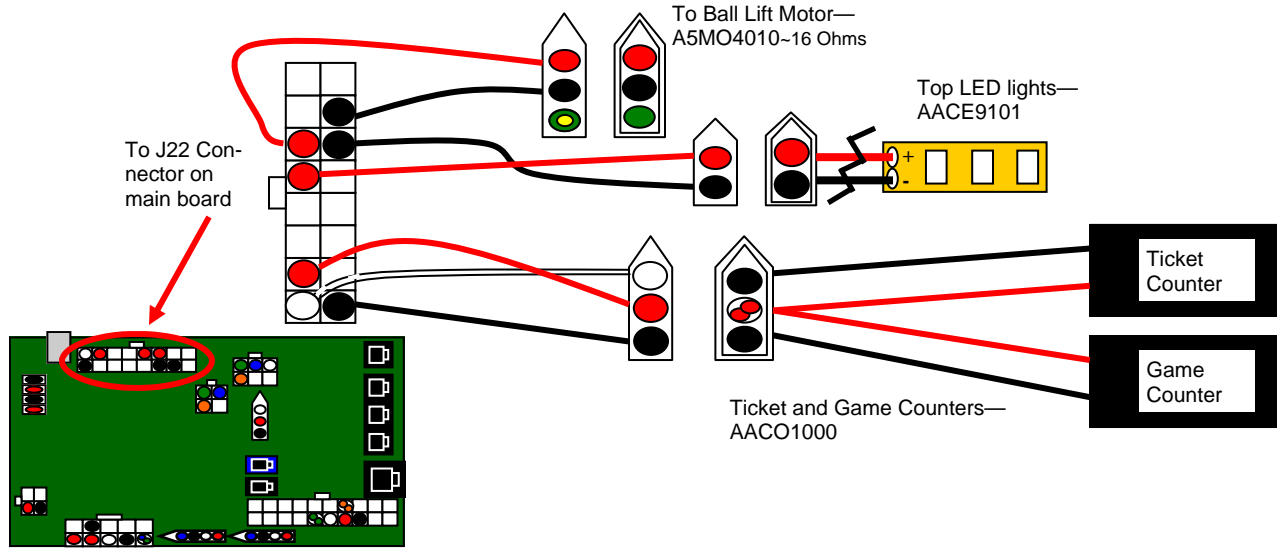

## Ticket Dispenser / Low Ticket Switches Display

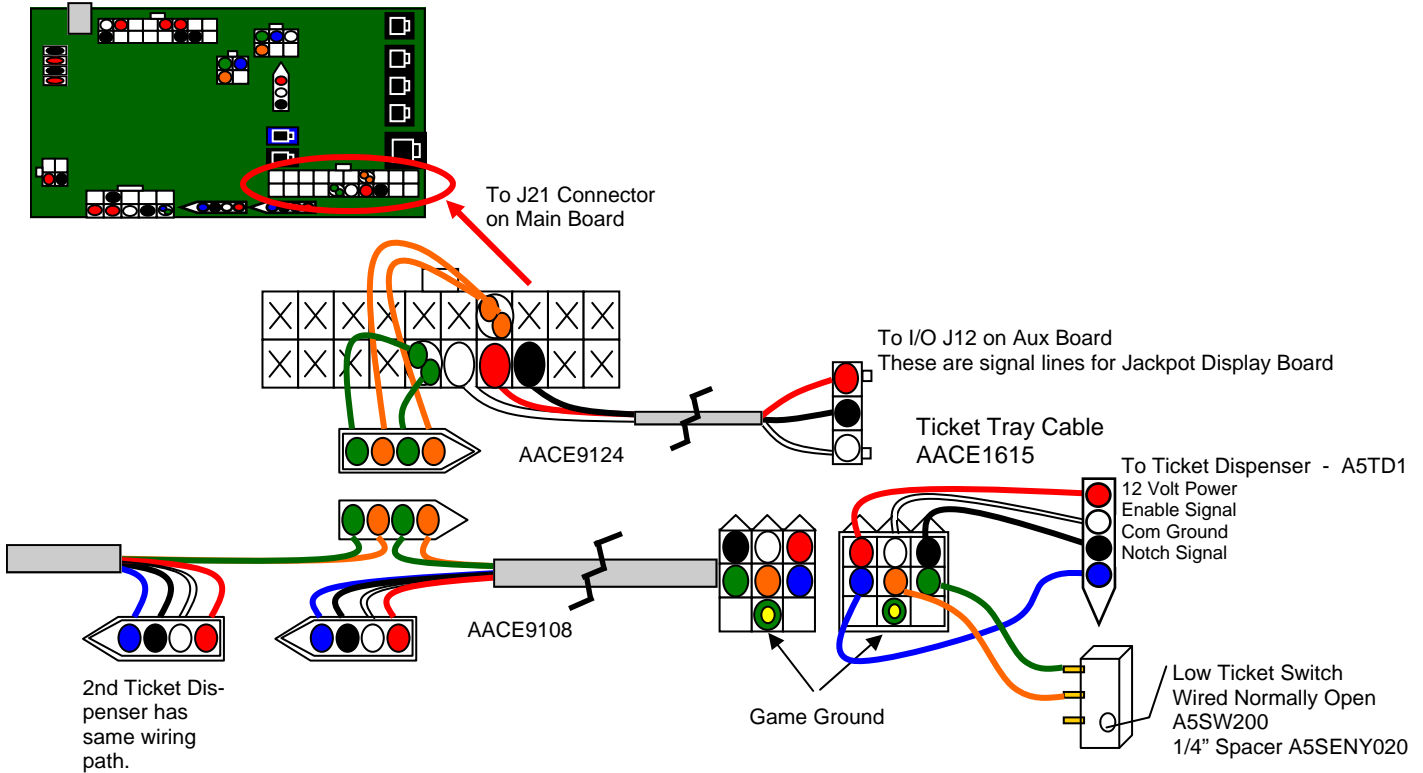

# 12 Volt Power Supply Wiring

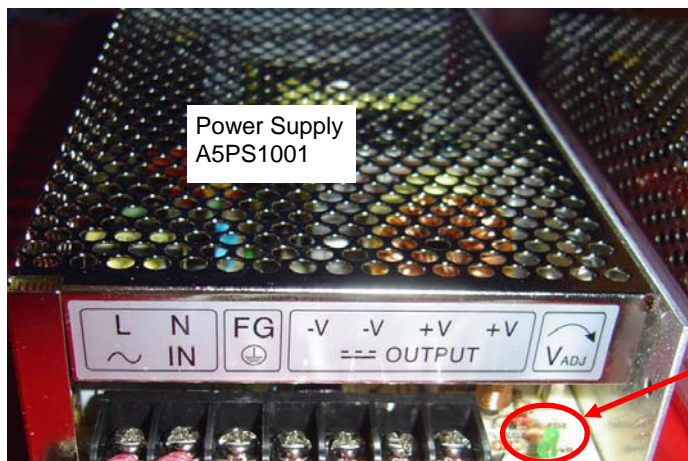

Green LED  
power indicator  
and voltage  
adjustment pot

Power Supply  
Power Cable  
AACE9105



Power Supply  
12 Volt Cable  
AACE9115

To J18 Con-  
nector on I/O  
AUX Board

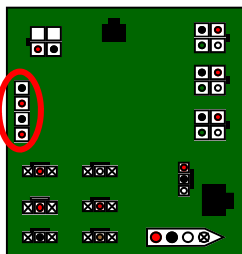

To J18  
"POWER IN"  
Connector on  
Main Board

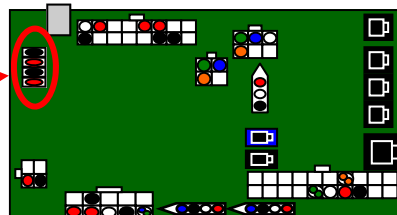

# Ball Sensor Wiring Diagram

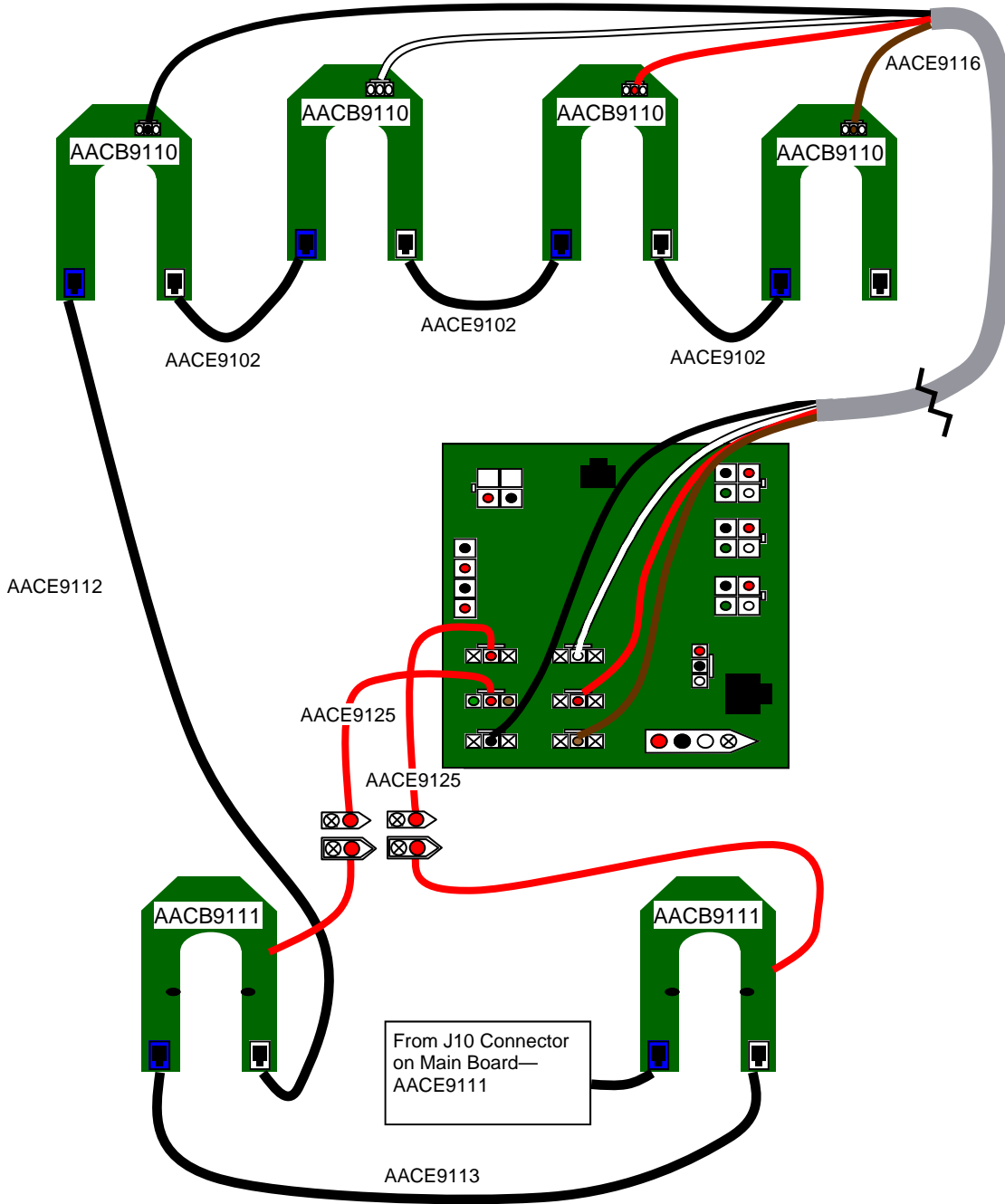

# Ball Sensor, Ball Release, Jackpot Display and Flipper Wiring

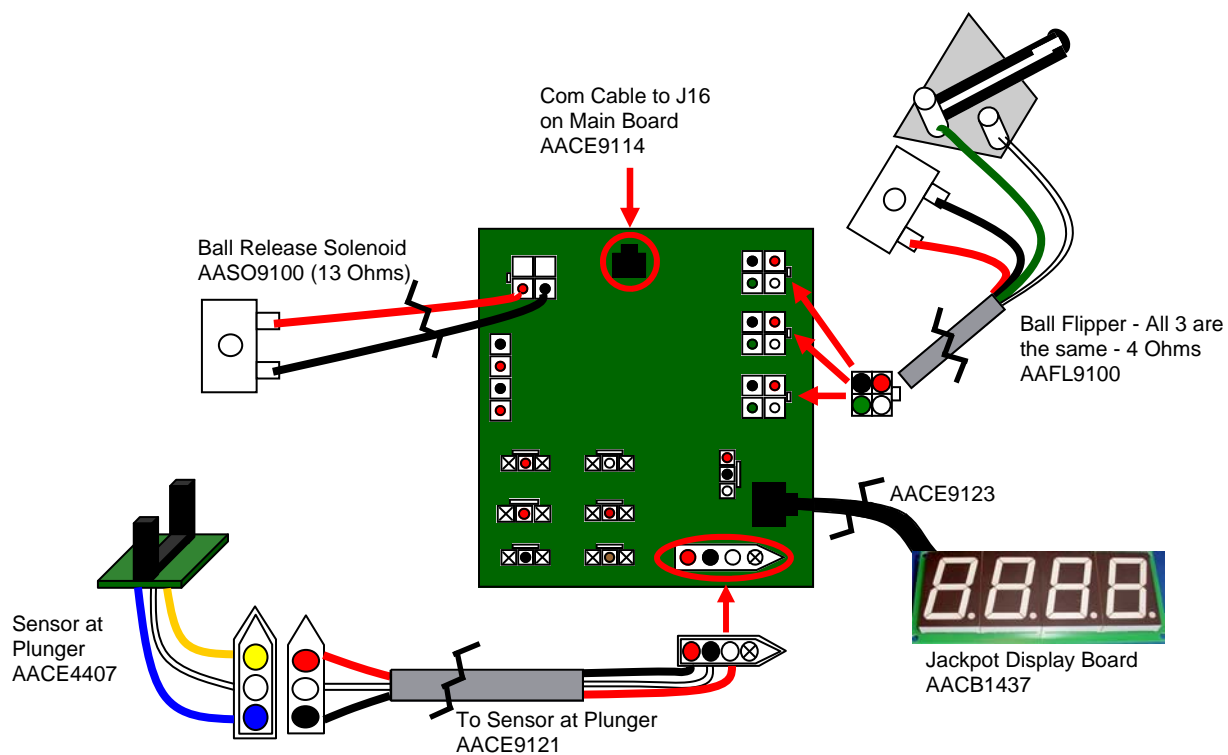

# TROUBLE SHOOTING GUIDE

## Troubleshooting Strategy

Use common sense and a systematic method of troubleshooting to determine the exact problem, probable cause and remedy. Use the process of elimination to find the faulty component. Always check for the simple and obvious causes first such as unplugged, loose or broken wires and bad sensors, bent, pinched, stuck or jammed components.

Troubleshooting Chart		
Problem	Probable Cause	Remedy
<b>No power to the game. No lights on at all.</b>	Unplugged.  Circuit breaker tripped.  Power strip faulty. Faulty cable/power supply.	Check wall outlet.  Reset power strip breaker switch or building circuit breaker. Change plug position, replace if needed. See Power Supply diagnostic below.
<b>AC Light and Bill Acceptor on. But everything else off.  (Power Supply not ON)</b>	Power supply unplugged.  Power supply shutting down because of 12 V overload.  Faulty power supply.	Insure unit is plugged into power strip.  See power supply diagnostics to isolate bad component. A bad motor or 12 volt short would cause this.  See Power Supply Diagnostic below.
<b>Dollar Bill Acceptor not functioning.</b>	Check for power to Bill Acceptor.  Dirt or debris in acceptor slot.  Pinched, broken, or disconnected wiring.  Bill acceptor problem.	Acceptor should cycle stacker at game power up. If not, check cable connections.  Refer to “How to Clean Bill Acceptor” Or clean with bill reader cleaning card. (A5CC9000)  Check wiring from bill acceptor to Main Board. (AACE9109) Repair or replace wiring harness. Check J8 connector on MainBoard—Make sure wires are secure in connector.  Refer to troubleshooting section of dollar bill acceptor manual included with this game or the diagnostics label of the back of the unit.
<b>Game not coining up.</b>	Ensure game makes “Dong” sound when coin switch is triggered.  Game set to large amount of credits per game.	Check coin switches—both should be wired normally open. Check wiring to main board. Cable AACBL4A-DOOR, AACE9109  Jackpot display will show credits inserted. Enter N2 mode in menu to set credits per game.

# TROUBLE SHOOTING GUIDE

Problem	Probable Cause	Remedy
<b>Game scores wrong values</b>	<p>Game is scoring too soon – before coin reaches sensor.</p> <p>Players think they won bonus.</p>	<p>Faulty sensor – Align and clean sensors or replace sensor. (AACB9110 - Top row sensor) (AACB9111 - Bottom row sensor)</p> <p>“Skill Shot” values are constantly changing and are on a set timer. The value on the target at instant ball passes sensor is what the player receives.</p>
<b>Game does not score target.</b>	<p>Back door removed or broken.</p> <p>Faulty target sensor.</p> <p>Disconnected, loose or broken wires.</p> <p>Faulty I/O Aux Board.</p>	<p>The back door has ball guides that help divert the ball. Replace back door. (AADO9100)</p> <p>Align and clean sensors or replace sensor. (AACB9110 - Top row sensor or AACB9111 - Bottom row sensor)</p> <p>Check connectors and clean phone jack sockets on I/O Aux Board and main board. Check for continuity. Cable #'s : 9116, 9125, 9124</p> <p>Check connections and clean phone jack sockets on Aux Board and main board.</p>
<b>Game pays 5 more tickets than it should.</b>		<p>One of the ticket dispensers is not seeing the notch signal. The dispenser will time out after 5 tickets.</p>
<p><b>Tickets do not dispense or Wrong amount dispensed.</b></p> <p><b>Check for the correct amount of tickets adding up on Tickets Owed Display</b></p>	<p>Tickets Owed Display is adding up correct.</p>	<p>Opto Sensor on ticket dispenser dirty.</p> <p>Faulty ticket dispenser.</p> <p>Notch on tickets cut too shallow.</p> <p>Faulty cable. Disconnected, loose or broken wires.</p> <p>Faulty Main Board.</p>
<p>Tickets Owed Display is not adding correctly</p>	<p>Game is scoring too soon – before coin reaches Slot sensor board.</p> <p>Ensure “Skill Shot” values are changing on display above sensor. The values are constantly changing and are on a set timer.</p>	<p>Blow dust from sensor and clean with isopropyl alcohol.</p> <p>Replace with working dispenser to isolate the problem. (A5TD1)</p> <p>Flip tickets and load upside-down to have large cut notch toward opto sensor.</p> <p>Check connectors from ticket dispensers to main board. Check for continuity. Check cables 1615, 9108</p> <p>Replace main board.</p> <p>Score sensor is faulty. Align and clean sensors or replace sensor. AACB9110 - Top row sensor AACB9111 - Bottom row sensor</p> <p>The value on the target at instant ball passes sensor is what the player receives.</p>

# TROUBLE SHOOTING GUIDE

Problem	Probable Cause	Remedy
<b>No Sound</b>	<p>Volume set to zero in menu.</p> <p>Disconnected, loose or broken wires.</p> <p>Faulty speaker.</p>	<p>Enter N6 in menu for game volume. Enter N7 in menu for attract volume.</p> <p>Check connections and reseal J19 on main board. Cable # AACE9100</p> <p>Replace speaker. A5SP1050</p>
<b>Targets not lighting up</b>  Note: Target lights are wired separate from target sensors.	<p>Targets are wired in series. If one is faulty, all of the targets after it will go dark.</p> <p>Check previous target and target which is dark.</p> <p>Swap target boards to isolate problem.</p> <p>Faulty target sensor.</p>	<p>Refer to Ball Sensor Wiring Diagram. Cable goes from Main Board to bottom sensors to top sensors.</p> <p>Check connections and clean phone jack sockets on targets and main board.</p> <p>Note: Top row sensors are different from bottom row sensors.</p> <p>Replace sensor. AACB9110 - Top row sensor AACB9111 - Bottom row sensor</p>
<b>Jackpot Display not lighting up</b>	<p>Phone Cable to Display is bent, pinched or unplugged.</p> <p>J12 connector on I/O Aux Board to main board disconnected.</p> <p>Faulty Display Board.</p>	<p>Check connections and clean phone jack sockets on display board and I/O Aux board. Replace cable if needed. AACE9123</p> <p>Check connections and reseal J12, and J21 on main board. Cable # AACE9124</p> <p>Replace Display Board. AACB1437</p>
<b>Jackpot Display says "Lo"</b>	<p>Both ticket trays are empty.</p> <p>Disconnected, loose or broken wires.</p> <p>Faulty low ticket switches.</p> <p>Faulty Main Board.</p>	<p>Refill trays with tickets.</p> <p>Check connections and reseal J21 on main board. Cable #'s 9124, 9108, 1615</p> <p>Switches wired normally open. Replace switches. A5SW200</p> <p>Replace main board. Part # AANEWGEN1</p>
<b>Game looks fine, but none of the functions work.</b>	<p>I/O Aux Board may be faulty, wires disconnected from main board, or not receiving 12 VDC power.</p>	<p>Check I/O Aux Board for any disconnected wires.</p> <p>Check 12 Volts DC to J18.</p> <p>Check J16 plug on I/O Aux Board to J21 on main board.</p>

# TROUBLE SHOOTING GUIDE

<b>Display shows Err 1</b>	<p>Err 1 means there is no ball in front of plunger after coin up. There can be multiple causes, including:</p> <table style="width: 100%; border: none;"> <tr> <td style="width: 50%; border: none;">Not enough balls in game.</td> <td style="width: 50%; border: none;">Ensure 16 balls in game.</td> </tr> <tr> <td style="border: none;">Playfield Kicker not working.</td> <td style="border: none;">Refer to Playfield Kicker not working below.</td> </tr> <tr> <td style="border: none;">Ball Load motor not working.</td> <td style="border: none;">Refer to Ball Load Motor not working below.</td> </tr> <tr> <td style="border: none;">Ball release solenoid not working.</td> <td style="border: none;">Refer to Ball Release Solenoid not working below.</td> </tr> <tr> <td style="border: none;">Ball load sensor not seen.</td> <td style="border: none;">Clean or replace sensor. AACB1901</td> </tr> </table>	Not enough balls in game.	Ensure 16 balls in game.	Playfield Kicker not working.	Refer to Playfield Kicker not working below.	Ball Load motor not working.	Refer to Ball Load Motor not working below.	Ball release solenoid not working.	Refer to Ball Release Solenoid not working below.	Ball load sensor not seen.	Clean or replace sensor. AACB1901
Not enough balls in game.	Ensure 16 balls in game.										
Playfield Kicker not working.	Refer to Playfield Kicker not working below.										
Ball Load motor not working.	Refer to Ball Load Motor not working below.										
Ball release solenoid not working.	Refer to Ball Release Solenoid not working below.										
Ball load sensor not seen.	Clean or replace sensor. AACB1901										

Problem	Probable Cause	Remedy
<p><b>Playfield Flipper not working.</b></p> <p><b>One ball stuck in front of Flipper</b></p> <p>Swap inputs on I/O Aux board to verify flipper fault.</p>	<p>Switch not making contact on flipper assembly.</p> <p>Disconnected, loose or broken wires.</p> <p>Flipper solenoid faulty.</p> <p>Problem may follow socket on I/O Aux Board.</p>	<p>Inspect flipper assembly, replace if needed. AAFL9100</p> <p>Check connectors from flipper to I/O Aux Board.</p> <p>Replace flipper. (4 Ohms) AAFL9100</p> <p>Replace I/O Aux Board. AACB9107</p>
<p><b>Ball Load Motor does not work.</b></p> <p><b>Ball loader will load ball at coin up if no ball is at plunger, then cycle 15 seconds twice, then go to Err1. It will try again after 40 seconds.</b></p>	<p>Disconnected, loose or broken wires.</p> <p>Faulty Motor.</p> <p>Faulty Main Board.</p>	<p>Check connectors from Motor to Main Board.</p> <p>Replace Motor. A5MO4010</p> <p>Replace Main Board. AANEWGEN1</p>
<p><b>No Balls on playfield.</b></p> <p>If no ball is preset at coin up, game will load one immediately and then try again after 15 seconds.</p>	<p>Sensor at Plunger blocked or faulty.</p> <p>Faulty Ball Load Motor</p> <p>I/O Aux Board is not communicating.</p>	<p>Clean sensor, check for toggle movement. Replace sensor. (AACE4407)</p> <p>Refer to Ball Load Motor does not work above.</p> <p>I/O Aux Board may be faulty, wires disconnected from main board, or not receiving 12 VDC power.</p>
<p><b>Too many balls on playfield</b></p>	<p>Ball Lift Sensor faulty causing load motor to always turn.</p> <p>Ball Flipper switch faulty causing game to keep loading balls because it can not find them.</p> <p>Ball Flipper Solenoid faulty.</p> <p>Sensor at Plunger faulty.</p>	<p>Clean sensor. Check wiring. Replace sensor. (AACB1901)</p> <p>Check continuity through switch. Swap Flipper to isolate problem. Replace flipper (AAFL9100)</p> <p>Swap Flipper to isolate problem. Replace flipper- 4 Ohms (AAFL9100)</p> <p>Sensor does not see ball in position, so game continues to load balls. Replace sensor. (AACE4407)</p>

# TROUBLE SHOOTING GUIDE

Problem	Probable Cause	Remedy
<b>Ball release solenoid not working.</b>	Disconnected, loose or broken wires. Faulty solenoid.	Check connectors from Ball Release Solenoid to I/O Aux Board Check for 13 Ohms across coil. Replace if needed. AASO9100
<b>Too many balls on playfield</b>	I/O Aux Board connection. Faulty I/O Aux Board.	Ensure I/O Aux Board has 12 Volt power on J18. Check J16 Com cable. Replace I/O Aux Board. AACB9107

## More information on the I/O Aux Board

The I/O Aux Board has logic on board which monitors sensor inputs and provides 12 volt pulses to coils to operate. It provides this information back to main board via the J16 Communication cable. (AAACE9114)

It is important that this cable is securely connected to the J16 socket on the main board. (Blue colored socket)  
Power game down when disconnecting and reconnecting this cable. Wait 10 seconds before power up.

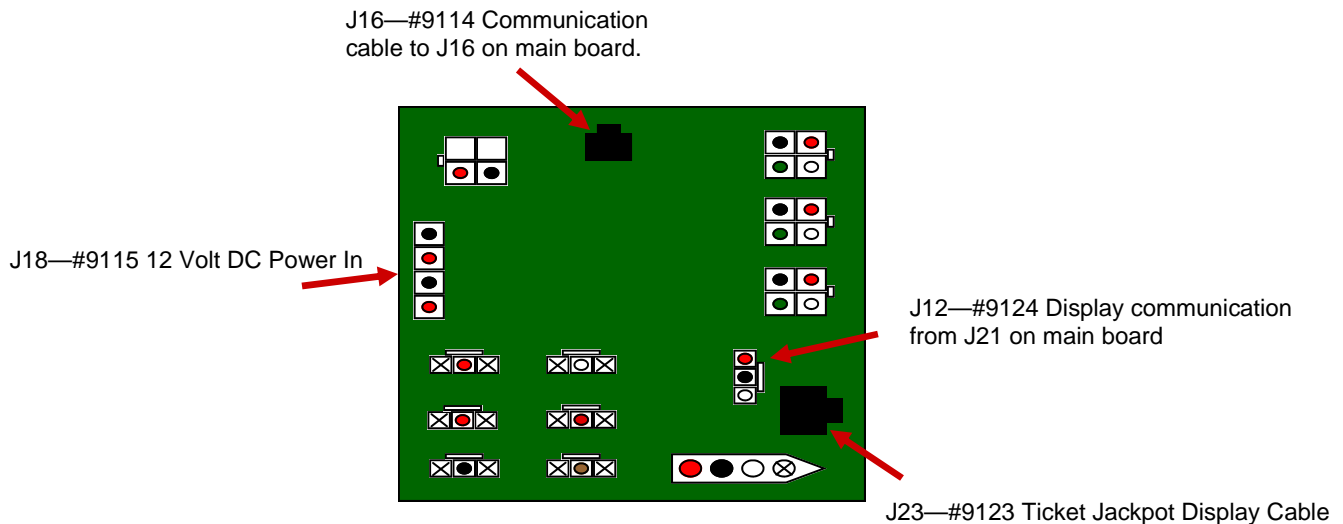

The I/O Aux Board also acts as a connector board for Jackpot Display Board.  
Signals come in on J12, and go to display on J23.

Jackpot Display will not work if either cable is faulty.

# POWER SUPPLY DIAGNOSTICS

Use the following procedure to check the Power Supply for Gen 5 games.

Start by removing the backdoor to gain access to the Power Supply. It is mounted directly to the left of the PCB.

Look for the small green LED light on the Power Supply circuit board. If the light is out there is a short somewhere. If the light dims, there is an overload in one of the circuits such as a bad motor.

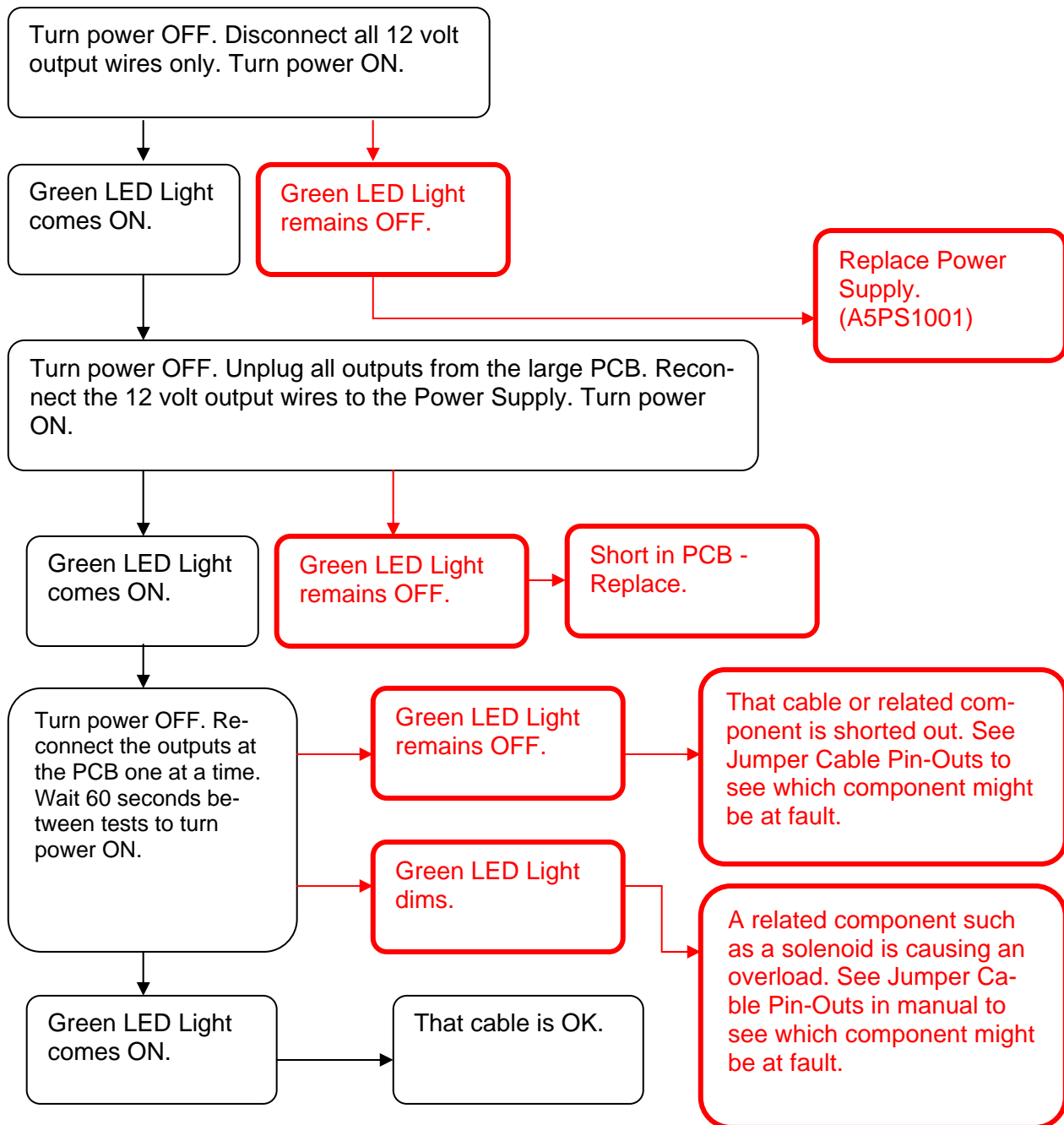

# BILL ACCEPTOR DIAGNOSTICS

**Note: There are many different models and brands of Bill Acceptors that are used on redemption games. Your Bill Acceptor may differ from the unit shown.**

First determine if Bill Acceptor has power:

Turn game ON—The bill acceptor should make noise as stacker cycles and green lights on outside bezel should flash.

If NO power:

Due to the different models and brands of Bill Acceptors that are used: Examine Bill Acceptor and determine if acceptor is 12 Volt DC or 110 VAC Use meter to measure voltage at cable going into Bill Acceptor.



If power is OK:

Clean Bill Acceptor path to make sure there is nothing jamming unit.

Enter DBA Diagnostics Mode -

**Important—Do not hold button down for more than 5 seconds or Bill Acceptor will enter programming mode.**

If programming mode is entered by mistake—Unplug game and plug back in.

To enter Diagnostic Mode, press and hold the Diagnostic Button on the back left corner of the DBA for **1-3 seconds.**

The lights above the bill slot will flash the code.



## ERROR CODES

Count the number of flashes on front bezel of Bill Acceptor and follow chart for repair.

FLASHING CODE	DESCRIPTION	CORRECTIVE ACTION
LEDs off	Power off	Turn on power
LEDs on	Acceptor is OK	
1 flash	Bill path blockage	Un-jam bill path
2 flashes	Stacker jam	Un-jam stacker
3 flashes	Cassette is full of bills	Empty the cassette
4 flashes	Cassette is removed	Replace the cassette
5 flashes	Acceptor is defective	Replace the acceptor
6 flashes	Acceptor not enabled	See service manual
10 flashes	Configuration Mode	Power down to exit
Rapid flashing during operation	Stringing attempt detected; or sensors dirty	Clean the sensors



# PARTS LIST

PART #	DESCRIPTION
A5BA9100	Ball, Purple, 16 Per Game
A5CB1499	Coin box
A5CO4203	Speaker cover
A5FI9010	Inline Filter
A5HU1200	Hub
A5LI0001	Fluorescent light, 120v 60hz
A5LK2000	631 Lock with Keys
A5LK5001	644 Lock with Keys
A5LK6000	Back Door Lock with Keys
A5LE9100	Large Leaf, 4 Per Game
A5MO4010	Motor
A5PL9097	Plate, (Replaces Bill Acceptor)
A5PS1001	Power Supply
A5SP9103	Spring, Pin, 32 Per Game
A5SP9104	Spring, Ball Guide
A5SW200	Switch
A5TD1	Ticket Dispenser
A5VF9100	Vacuum Form, Purple Marquee
A5VF9101	Vacuum Form, Playfield Ball Guide
A5ME9129	Metal, Target Sensor Cover

A5DE9109	Decal, Marquee, Title Bubble
A5DE9110	Decal, Marquee, Face
A5DE9111	Decal, Marquee, Arm
A5DE9112	Decal, Marquee, Body
A5DE9114	Decal, Marquee, Right Ear
A5DE9115	Decal, Marquee, Bubble 1
A5DE9116	Decal, Marquee, Bubble 2
A5DE9117	Decal, Inside Marquee
A5DE9118	Decal, Playfield Cover, Left
A5DE9119	Decal, Playfield Cover, Right
A5DE9120	Decal, Marquee, Left Ear
A5DE9124	Decal, Left Light Cover
A5DE9125	Decal, Right Light Cover
A5DE9126	Decal, Back Door Cover

PART #	DESCRIPTION
A5CA1002	Caster, Wheel
W5TM4006	T-Molding, 13/16" Yellow
AACO1000	Counters
AALIHL110	Fluorescent Light Holder Assy.
AACE8802	Outlet Strip
AACE9122	Ball Release Solenoid W/Cable
AAPB2700	Push Button Assy. (Menu Button)
AACE8811	Speaker Assy W/Cable
AACB9101	Lights on Top of Playfield
AACB9107	Goes to Menu Button
AACB9124	Low Ticket to Aux Board
AACBL4A-DOOR	Door Cable
AACE4319	Fluorescent Light Cable
AACE9100	Speaker to Playfield Lights
AACE9103	Fl. Light to Motor to Ticket Counters
AACE9104	Top Marquee Fluorescent Light Wire
AACE9105	Power Supply Wire
AACE9108	Main Board to Ticket Tray
AACE9109	DBA to Coin Door
AACE9110	Slot Sensor to Auger to Fluorescent Light
AACE9115	Power Supply to Main Board to Aux Board
AACE9117	Cable to Flipper Solenoid, 2 Per Game
AACE9120	Cable to Flipper Solenoid, 1 Per Game
AACE9121	Aux Board to Ball Sensor to #2 Target
AACE9125	Aux Board to #1 Target
AACB1437	Display Board, 4 Digit
AACB1901-1	Encoder Wheel Board
AACB9107	Aux Board
AACB9110	Back Target Board
AACB9111	Front Target Board
AANEWGEN1	Main Board
AASH9100	Shooter Assy. Purple W/Finger
AABR9100	Ball Release Assy.
AAFL9100	Flipper Assy.
AATG9100	Toggle Assy. Sensor at Shooter
AACB4401	Sensor at Shooter
A5ME9111	Front Metal Bracket

# PARTS IDENTIFICATION



**A5BA9100**



**A5TD1**

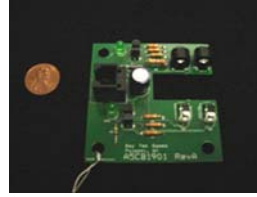

**AACB1901-1**



**AACB9107**

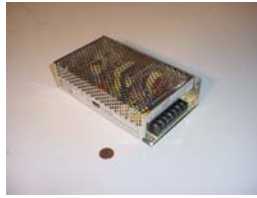

**A5PS1001**



**AANEWGEN1**

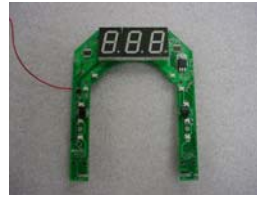

**AACB9111**



**AACB9110**



**AACB1437**



**A5LI0001**



**A5SP1050**



**AACO1000**



**AAPB2700**



**AALIHL110**



**A5LE9100**



**A5SP9103**



**A5SP9104**



**A5ME9129**



**A5MO4010**



**A5LK6000**



**A5LK2000**



**A5LK5001**



**A5CA1002**



**W5TM4006**

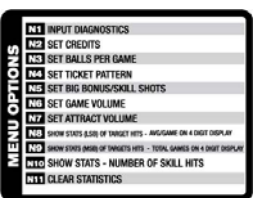

**A5DE9127**



**A5SW200**



**A5PL9097**



**A5CB1499**

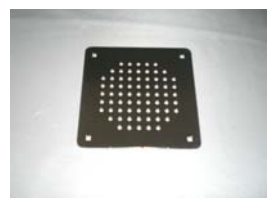

**A5CO4203**



**AABR9100**

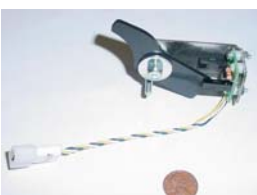

**AATG9100**



**AAFL9100**



**A5SH9100**



**AACB4401**

# PARTS IDENTIFICATION



**AACE1615**

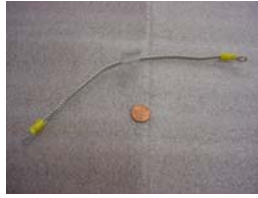

**AACE1715**



**AACE9100**

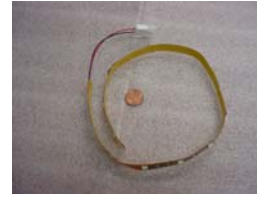

**AACE9101**



**AACE9102**



**AACE9104**



**AACE9105**



**AACE9106**



**AACE9107**



**AACE9108**



**AACE9109**



**AACE9110**



**AACE9111**



**AACE9112**



**AACE9113**



**AACE9114**



**AACE9115**



**AACE9116**



**AACE9117**



**AACE9118**



**AACE9119**



**AACE9120**



**AACE9121**



**AACE9123**



**AACE9124**



**AACE9125**



**AACBL4A-DOOR**



**A5FI9010**



**AACE9126**



**AACE9103**



**A5ME9111**

# DECAL IDENTIFICATION

## Pull My Finger - Decal Diagram

### MARQUEE DECALS:

- A5DE9109\_marquee title bubble
- A5DE9110\_marquee face
- A5DE9111\_marquee arm
- A5DE9112\_marquee body
- A5DE9114\_marquee ear right
- A5DE9115\_marquee bubble 1
- A5DE9116\_marquee bubble 2
- A5DE9120\_marquee ear left

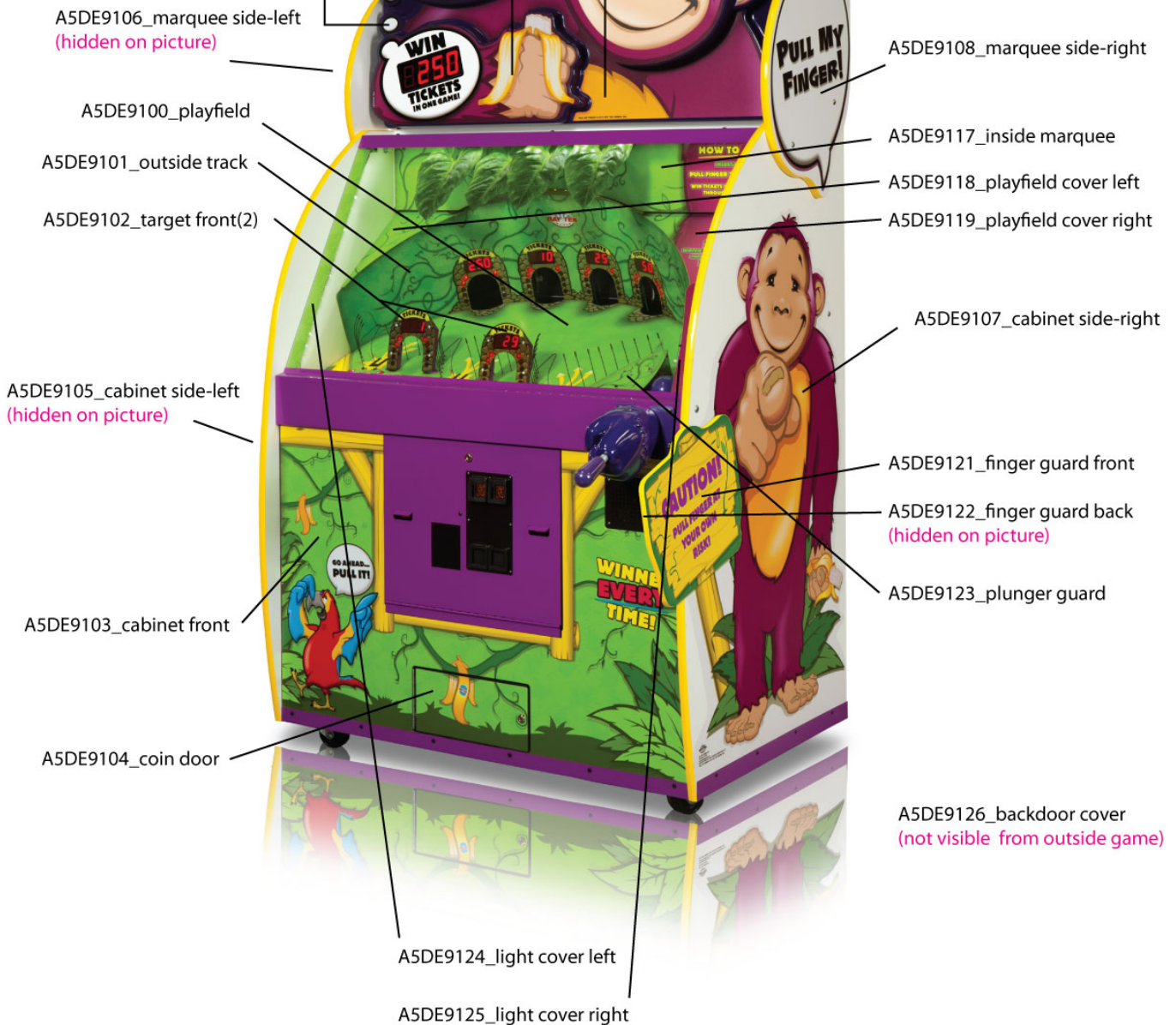

# WIRING DIAGRAMS

## NEWGEN1 MAIN BOARD

### BayTek Pull My Finger NEWGEN1 Hardware REV D Pinout - Version 1 (NO WHEEL VERSION)

Pin Type	Ref	Pin #	Purpose
LOWSIDE #1, w diod	J22	1	Wheel Motor Drive
LOWSIDE #2, w diod	J22	2	Ball Auger Drive
LOWSIDE #3	J22	3	White Playfield Lights
LOWSIDE #4	J22	4	Plunger "Ball Release Solenoid"
LOWSIDE #5	J22	5	Unused
LOWSIDE #6	J22	6	Unused
LOWSIDE #7	J22	7	Unused
LOWSIDE #8	J22	8	Mechanical Count #1
LOWSIDE #9	J22	9	Mechanical Count #2
+12 Volts	J22	11	
+12 Volts	J22	12	
+12 Volts	J22	13	
+12 Volts	J22	14	
+12 Volts	J22	15	
+12 Volts	J22	16	
+12 Volts	J22	17	
+12 Volts	J22	18	
+12 Volts	J22	19	
+12 Volts	J22	20	

Pin Type	Ref	Pin #	Purpose
Ground	J24	1	
Ground	J24	2	
+12 Volts	J24	3	
+12 Volts	J24	4	
PB7	J24	5	Auger Sensor Input 2
LOWSIDE #12	J24	6	Unused
PX29	J24	7	Auger Sensor Input
HIGHSIDE #10	J24	8	Unused
HIGHSIDE #11	J24	9	Unused
3.3V	J24	10	

Pin Type	Ref	Pin #	Purpose
PX37	J5	1	Ticket Notch #1
Ground	J5	2	Ground for Ticket Dispensor
PB18	J5	3	Ticket Motor #1
+12 Volts	J5	4	Power for Ticket Dispensor

Pin Type	Ref	Pin #	Purpose
PB16	J9	1	Ticket Notch #2
Ground	J9	2	Ground for Low Ticket Switch
PB17	J9	3	Ticket Motor #2
+12 Volts	J9	4	

Pin Type	Ref	Pin #	Purpose
PA05	J8	1	DBA Input
+12 Volts	J8	2	
Ground	J8	3	
Ground	J8	4	

Pin Type	Ref	Pin #	Purpose
HIGHSIDE #13	J25	1	
HIGHSIDE #14	J25	2	
PX10	J25	3	Service Button #1
PX11	J25	4	Service Button #2
Ground	J25	5	Ground for Service Buttons
Ground	J25	6	

Pin Type	Ref	Pin #	Purpose
+12 Volts	J6	1	Coin Door Power
PA05	J6	2	Coin Input
Ground	J6	3	Coin Ground

# WIRING DIAGRAMS, cont.

## NEWGEN1 MAIN BOARD

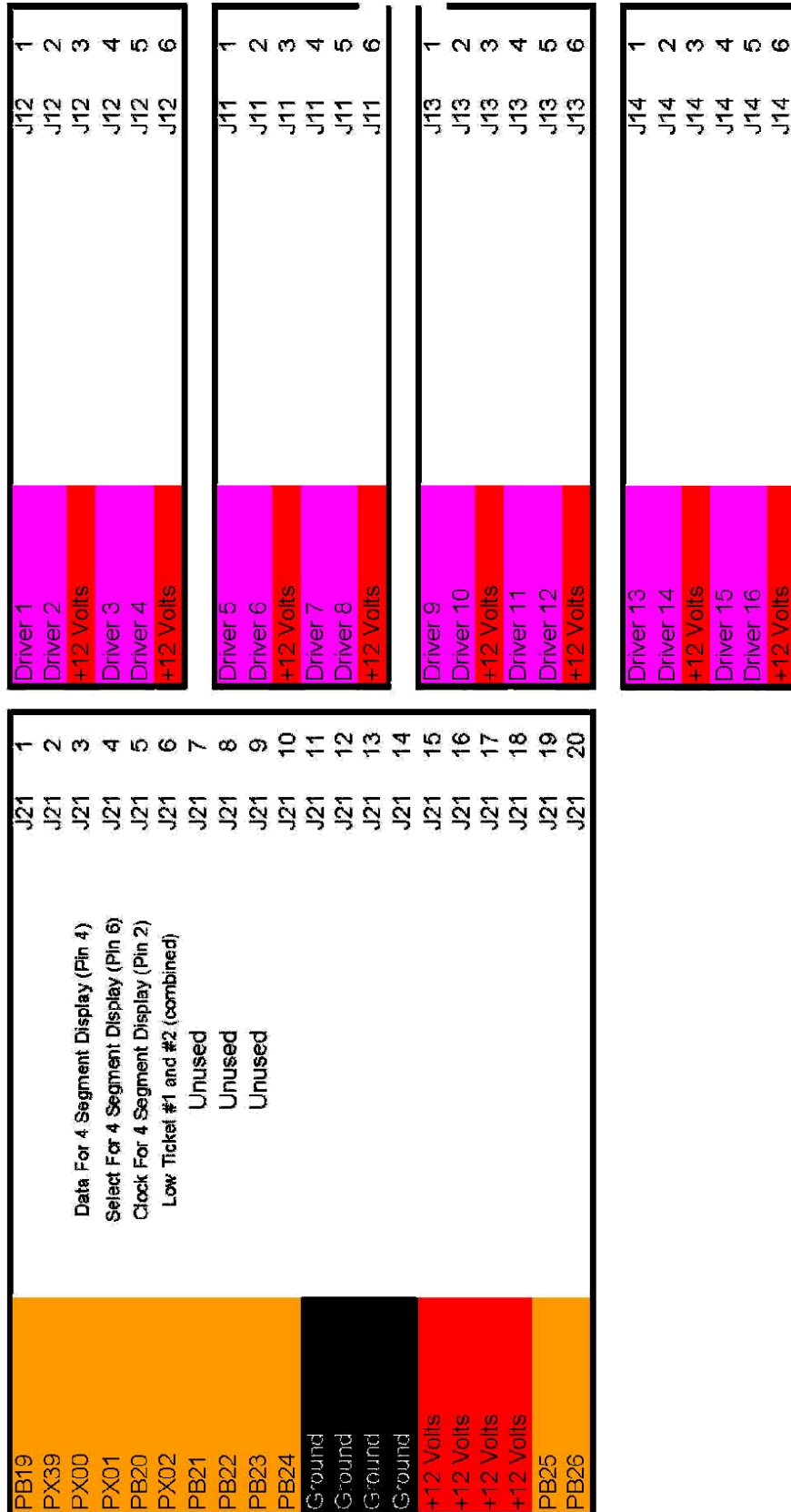

# WIRING DIAGRAMS, cont.

## NEWGEN1 MAIN BOARD

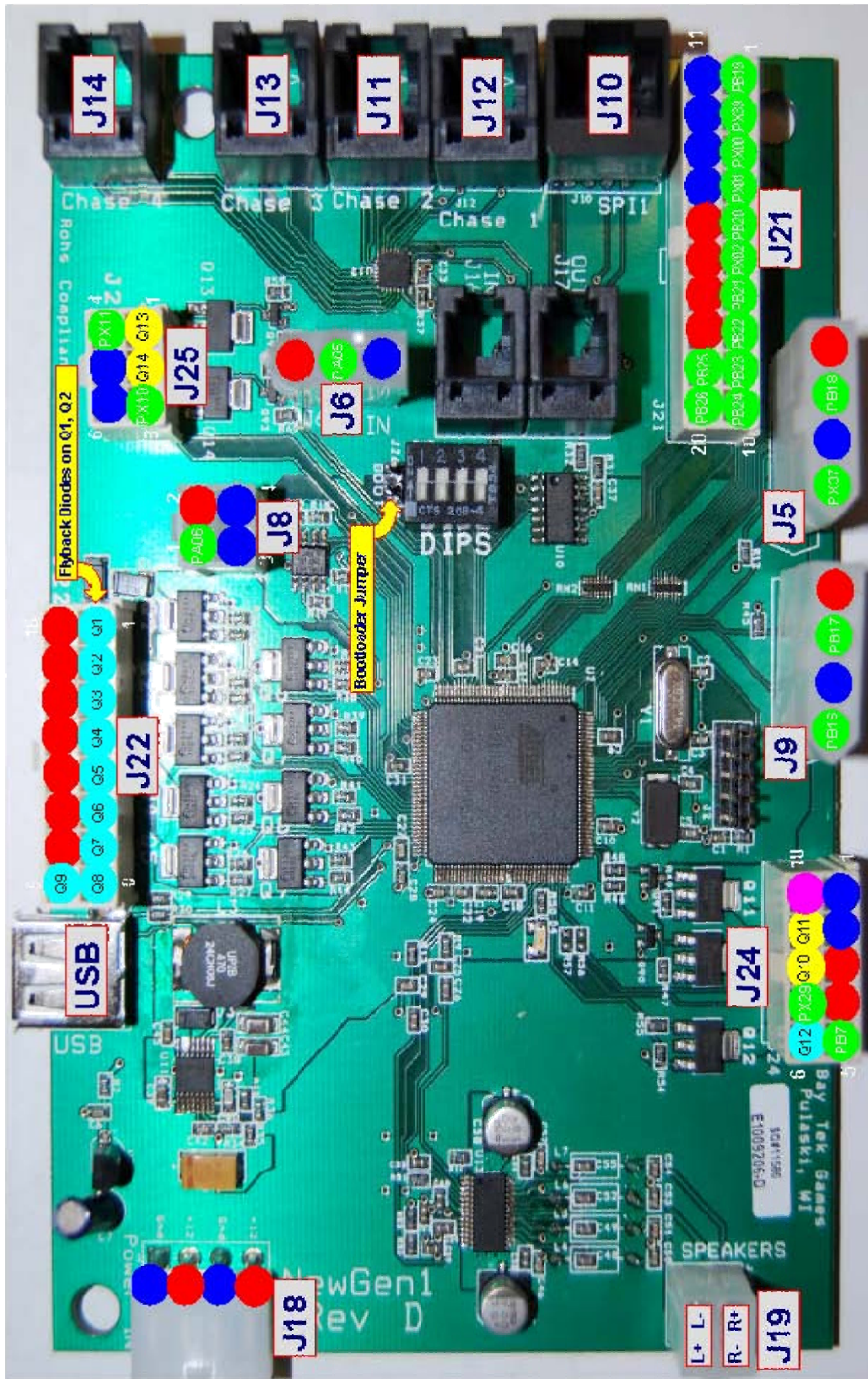

<ul style="list-style-type: none"> <li><span style="color: blue;">●</span> Ground</li> <li><span style="color: red;">●</span> +12V</li> <li><span style="color: cyan;">●</span> Low Side Driver</li> <li><span style="color: yellow;">●</span> High Side Driver</li> <li><span style="color: green;">●</span> +3.3V TTL Logic</li> <li><span style="color: magenta;">●</span> +3.3V</li> </ul>	<p><b>Main Board Dipswitches:</b></p> <ul style="list-style-type: none"> <li>Switch 1 is Double Decrement</li> <li>Switch 2 is Reverse ball gate - Do Not Use!</li> <li>Switch 3 is Jersey Shore Mode</li> <li>Switch 4 is Extra diagnostics - For programming Board. Do Not Use!</li> </ul>	<p>SPI Cut - Display - (c10)</p> <ul style="list-style-type: none"> <li>Pin 1 &amp; Pin 3 - +12V</li> <li>Pin 2 - SCLK_BUS2</li> <li>Pin 4 - SMDS_BUS2</li> <li>Pin 5 &amp; Pin 7 - Ground</li> <li>Pin 6 - SCSI2_BUS2</li> <li>Pin 8 - SM50_BUS2</li> </ul>	<p>Chase Lights (J11, J12, J13, J14)</p> <ul style="list-style-type: none"> <li>Fin 1 - Chase Output</li> <li>Fin 2 - Chase Output</li> <li>Fin 3 - +12V</li> <li>Fin 4 - Chase Output</li> <li>Fin 5 - Chase Output</li> <li>Fin 6 - +12V</li> </ul>
--	--	--	---

# WIRING DIAGRAMS, cont.

## PMF AUX BOARD

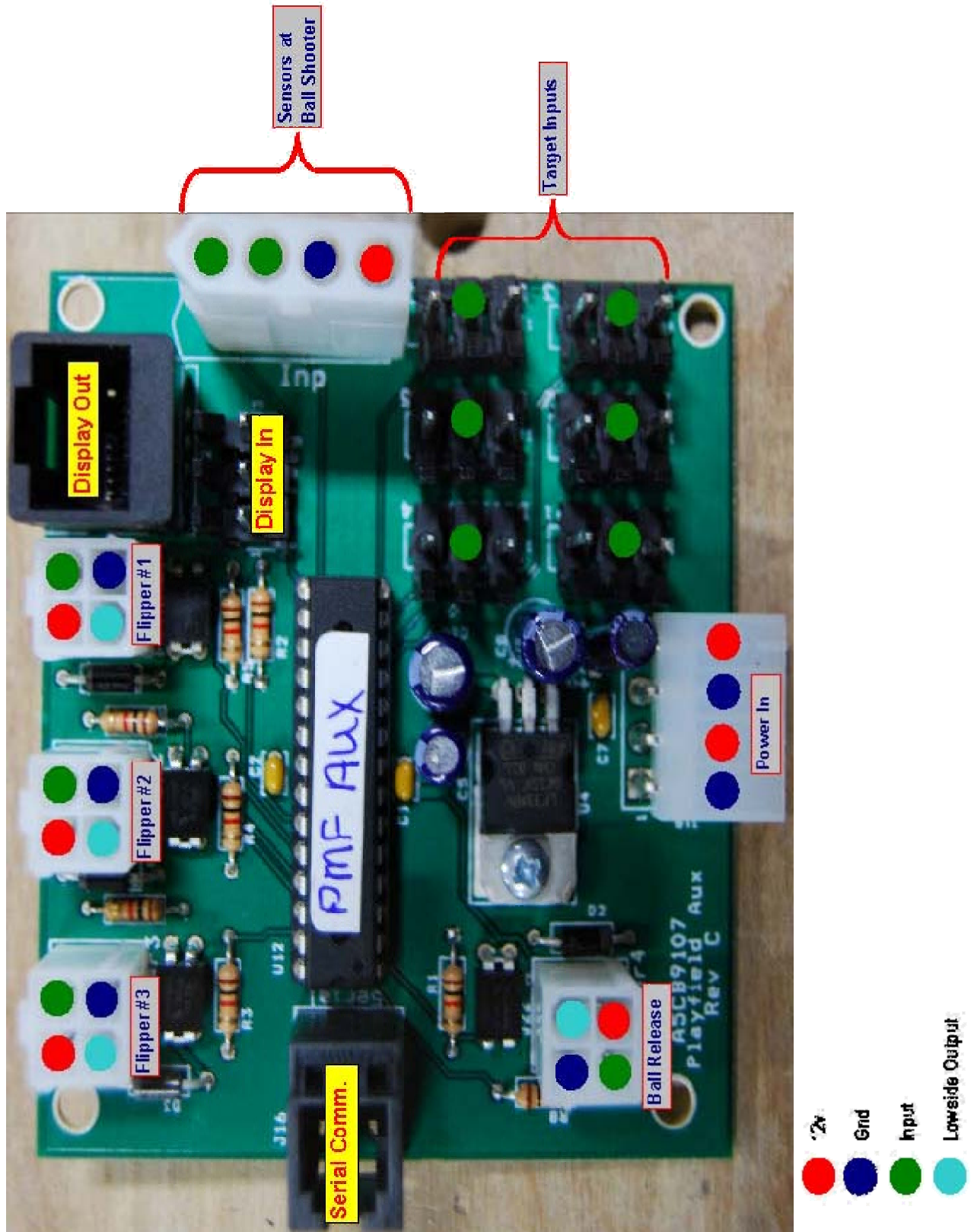



# TECHNICAL SUPPORT

Excellent customer service is very important to Bay Tek Games! We know that keeping your games in great operating condition is important to your business. When you need us, we are here to help. You can call us for free technical assistance, and you can count on us to have parts on-hand to support your game. When you do need us, it's important that you know what to expect. We offer options that fit your needs.

## **Electronics / Circuit Boards - Repair Options**

**Repair & Return** – If you have Circuit Board issues with your Bay Tek game, you can send the board to us and we'll repair it right away. Most items sent to us are repaired and returned to you within two days. This option is your best value as we offer this fast turn-around service at the most reasonable price.

**Advance Replacement** – If you have Circuit Board issues with your Bay Tek game, but you don't have time to send in your board in for repair, give us a call and ask for an Advance Replacement. We'll send you a replacement board that same day (pending availability). When you get your new board, just repackage the defective board in the same box and send it back to us. We make it easy by including a UPS Return Shipping label for you to put on the box (not available for international shipments). This is your best option when you need to get you game up and running as quickly as possible!

**Spare Parts** – Take matters into your own hands and purchase new spare Circuit Boards for your Bay Tek games. Many of our games share the same main-board electronics. This means you can buy one set of spare electronics to support many of your Bay Tek games. Spare boards allow you to get your game up and running the quickest and provide you a valuable troubleshooting option. Call our technicians to get recommendations for what you should keep on hand for spare parts!

## **Technical Support:**

"You" are the best tool for troubleshooting! Your abilities to understand the game and your skills to repair the game are invaluable to us! If you need help, you know you can call us. It's not easy to diagnose a game remotely by phone, but our technicians do a great job. They'll need your help to perform some troubleshooting steps and convey to them exactly what's happening with your game.

## **Returns, Credits, & Fees:**

**NOTICE!** ALL ITEMS being sent to Bay Tek Games for repair or return, etc. require prior Return Authorization! Bay Tek Games will provide a Product Return Form with an authorizing Ticket Number for each item to be returned. Please be certain to include this document with all shipments!

**Late Fees and Non-Return Fees** - Advance Replacement and Warranty Replacement items require the defective items to be returned by Bay Tek games promptly to avoid Late Fees. We would expect items to be returned with 10 working days. Late fees are invoiced monthly. Late fees are non-refundable under any circumstance! Any item not returned within 90 days will be invoiced in full as a replacement part!

**Bench Fees** - Bench fees will apply for each electronic item returned to Bay Tek Games (this includes unused Advance Replacement items). This charge covers our cost to inspect, evaluate and retest each item. Please note that returned items that do not pass our tests will be charged accordingly as replacement items or advance replacements.

**Restocking Fees** - Unused items returned for credit will be credited minus a restocking fee. Items must be returned within 30 days of purchase in order to qualify for any credit amount. No shipping charges will be credited.



# WARRANTY

Bay Tek Games warrants to the original purchaser that all game components will be free of defects in workmanship and materials for a period of 6 months from the date of purchase. If you fill out the registration card in the cashbox of the game, Bay Tek will add another 3 months to your warranty, free of charge.

Bay Tek Games will, without charge, repair or replace defective component parts upon notification to the parts/service department while the game is under warranty.

Warranty replacement parts will be shipped immediately, via ground service, along with a Product Return Form for the return of defective parts.

Defective parts must be shipped back to Bay Tek Games unless otherwise instructed. Items not returned to Bay Tek Games will be invoiced as replacement parts.

This warranty does not apply in the event of any misuse or abuse to the product, or as a result of any unauthorized repairs or alterations. The warranty does not apply if any serial number decal is altered, defaced, or removed from its original position.

	<b>ATTENTION</b>	
In order to maintain the safety & other compliance certifications of the game, ONLY approved parts may be used. For approved parts, refer to the parts list in this manual.		

Should you need your game serviced, determine the serial number from the decal placed on the front of this manual, or locate it on the back of the game. Then contact our Service Department at: 920.822.3951 or e-mail: [service@baytekgames.com](mailto:service@baytekgames.com)

# NON-WARRANTY

Options and estimated charges will be provided to you for your approval. Please remember that any items being sent to Bay Tek Games must include prior return authorization from our Parts & Service Department. This approval will include a Product Return Form which is required to be included with any incoming shipments. Repaired parts will be shipped back using the same method in which they were received. Repairs are warranted for 30 days from the date of return shipment.

# CERTIFICATE OF COMPLIANCE



## Declaration of Conformity

Manufacturer Identification	Equipment Identification
<b>Bay Tek Games, Inc.</b> 1077 East Glenbrook Drive Pulaski, WI 54162 U.S.A. <a href="http://www.baytekgames.com">http://www.baytekgames.com</a>	<b>Pull My Finger</b> Model: AAGM-PMF-220V  Type: Redemption Game

Council Directive 2004/108/EC		Electromagnetic Compatibility	
<b>Emissions Standard:</b> EN 55014-1: 2006 + A1:2009 + A2:2011		<b>Immunity Standards:</b> EN 55014-2: 1997 + A1:2001 + A2:2008	
Terminal Disturbance Voltage	150kHz - 30MHz	ESD	IEC61000-4-2:2008-12
Discontinuous Power	30MHz - 300MHz	Radiated Immunity	IEC61000-4-3:2006-02
<b>Emissions Standards:</b> EN 61000-3-2:2006 +A1:08 + A2:2009 Current Harmonics EN 61000-3-3:2008 Voltage Flicker		EFT	IEC61000-4-4:2004-07 + A1:2010
		Surge	IEC61000-4-5:2005-11
		Conducted Immunity	IEC61000-4-6:2008-10
		Power Dips and Interrupts	IEC61000-4-11:2004-03

Council Directive 2006/95/EC	Low Voltage
<b>Standards:</b> Household and similar electrical appliances - Safety - Part 1: General requirements, IEC 60335-1:2001 (4th Edition) (incl. Corrigendum 1:2002) +A1:2004 +A2:2006 (incl. Corrigendum 1:2006), and Part 2: Particular requirements for amusement machines and personal service machines, IEC 60335-2-82:2002 (2nd edition) +A1:2008 With differences according to EN 62233:2008	

I hereby declare, on behalf of the manufacturer above, that the equipment listed meets the requirements of all applicable Council Directives for CE Marking. Conformance was demonstrated by meeting the requirements of the referenced harmonized Standards.

Name	Title	Signature	Date
Gaetan Philippon	President	<i>Gaetan Philippon</i>	8-27-2012
Email: gphilippon@baytekgames.com		Phone: 920-82243951	

<b>Document Number:</b>	04262011.2
-------------------------	------------



“If we’re not having fun, something’s wrong.”

-Larry Treankler, CEO



PULL MY FINGER™  
IS A REGISTERED TRADEMARK OF  
BAY TEK GAMES, INC.



Pulaski Industrial Park  
1077 East Glenbrook Drive | Pulaski, Wisconsin 54162 USA  
(920) 822-3951 | fax: (920) 822-8936 | e-mail: sales@baytekgames.com

[www.baytekgames.com](http://www.baytekgames.com)